

Self recuperative ceramic burner REKUMAT® C150

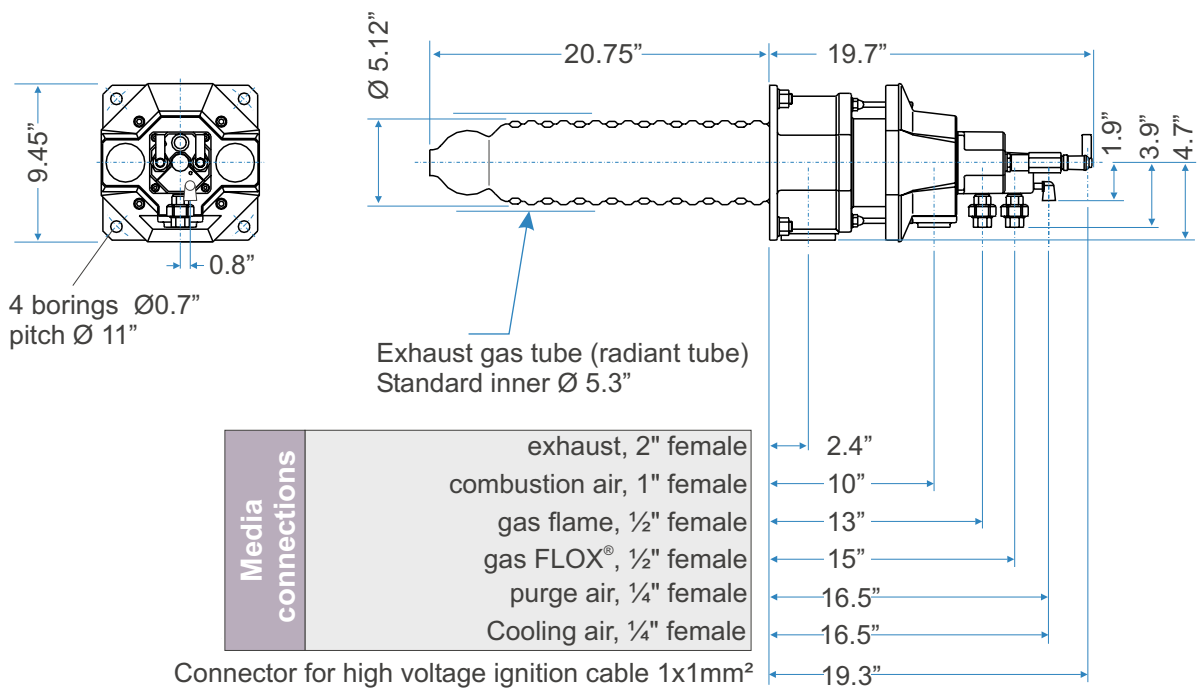

Possible orientation for media connections

The media connections for:

- exhaust gas
- combustion air
- gas, purge air

may be rotated in 90° intervals to achieve the desired orientation



costumization is possible

© 2001